

NXT Joystick

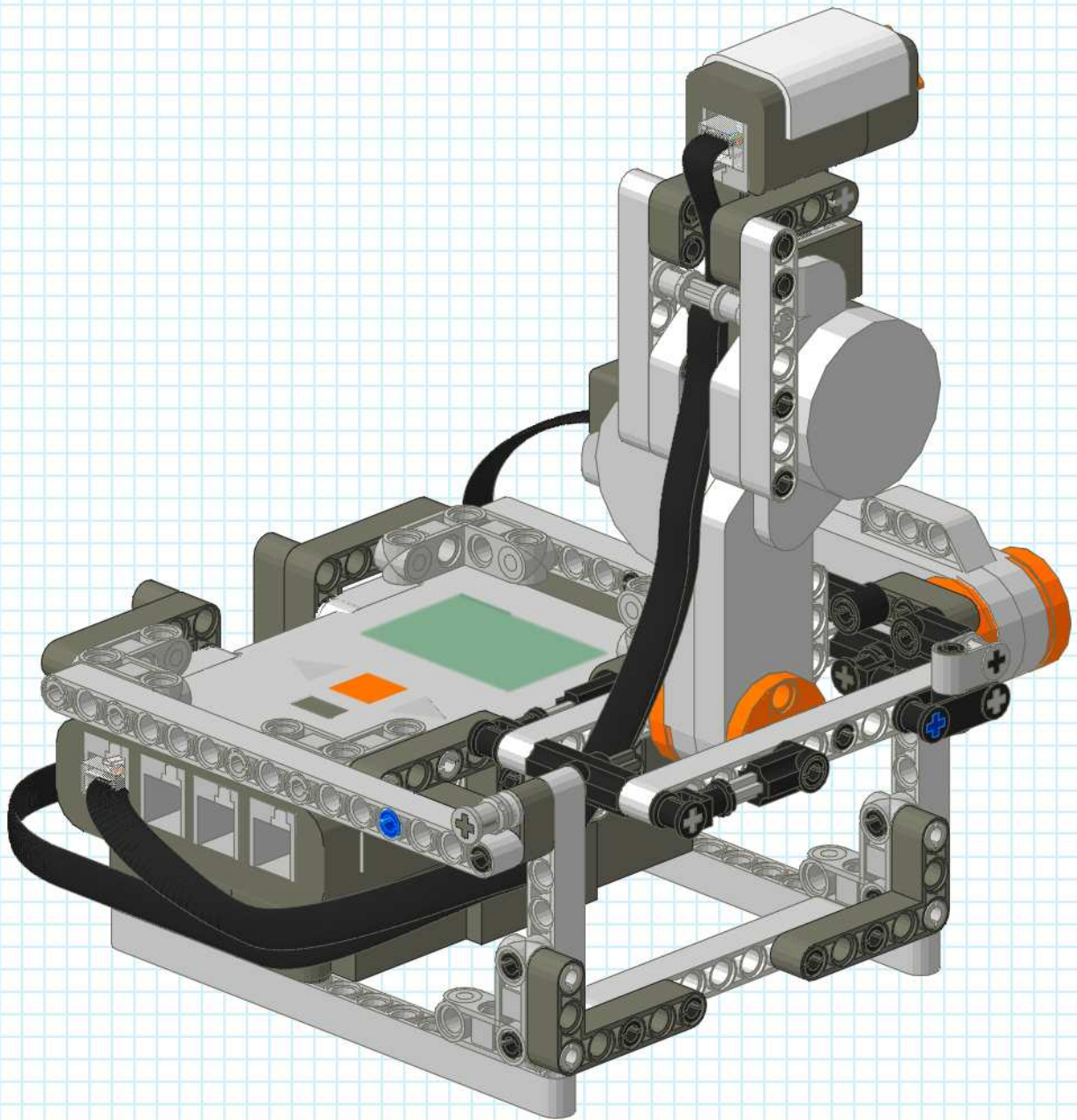

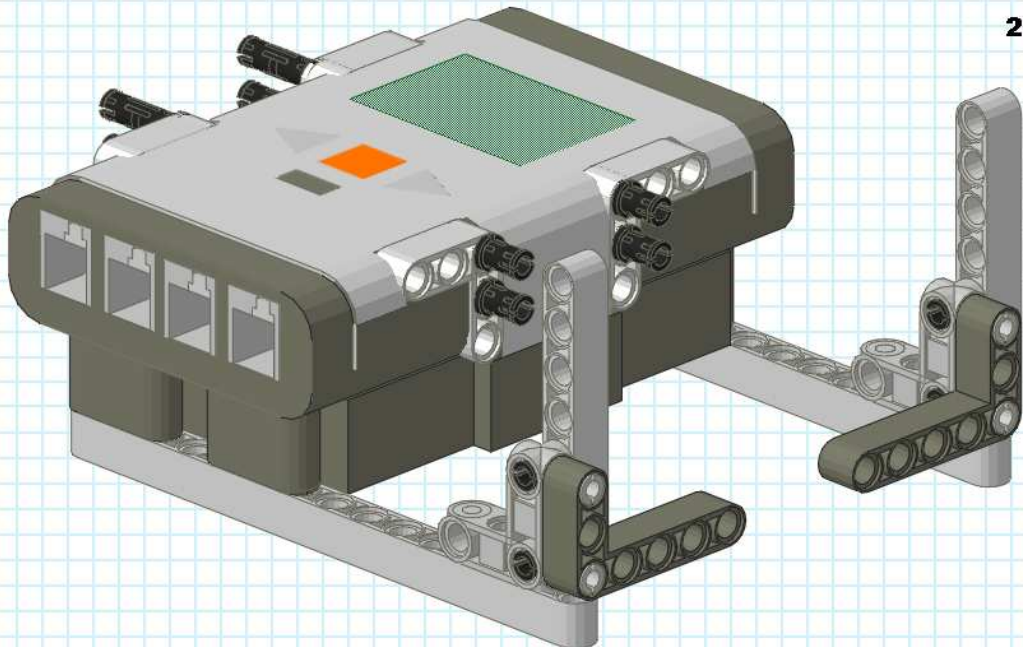

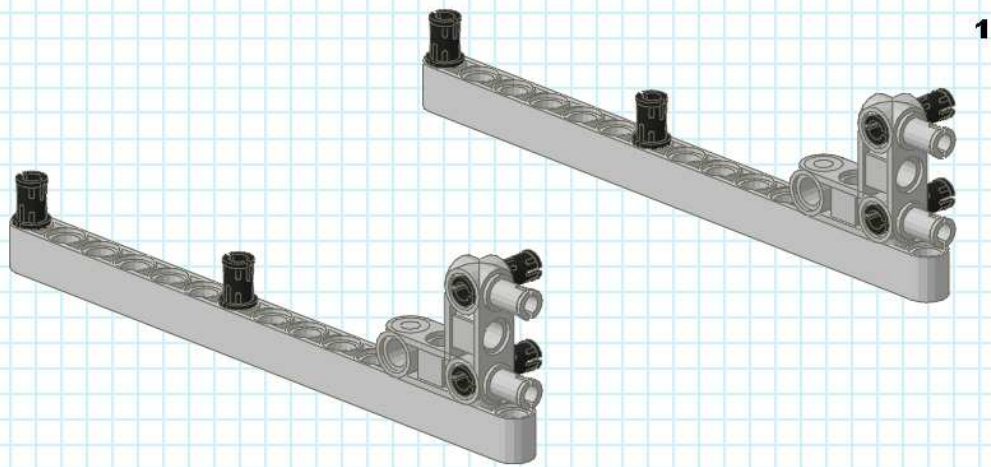

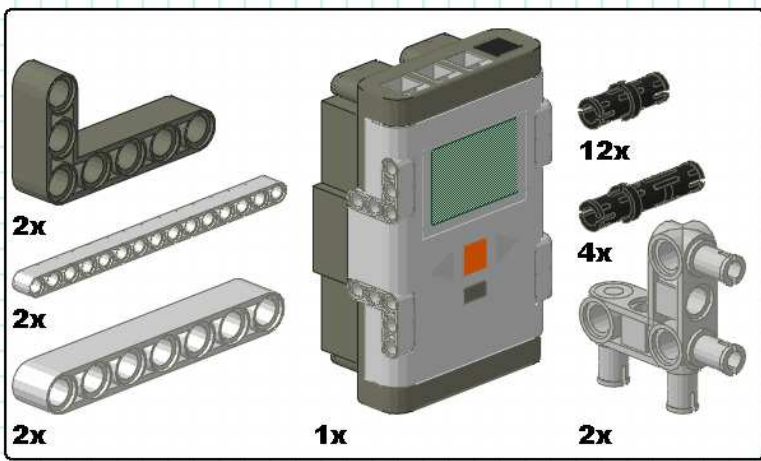
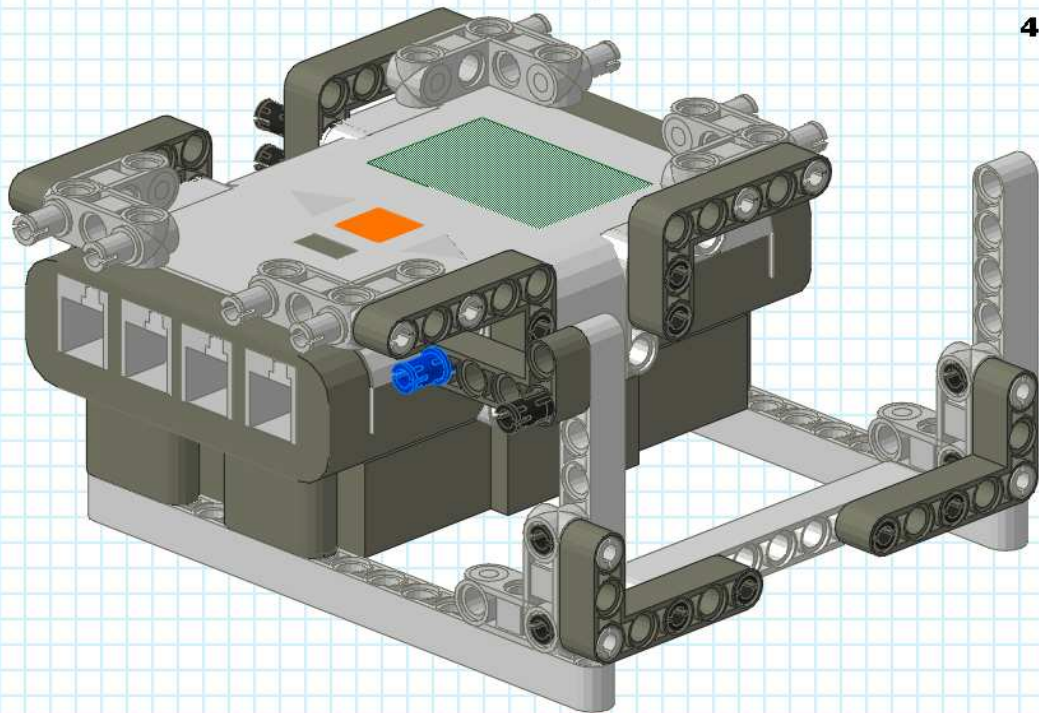
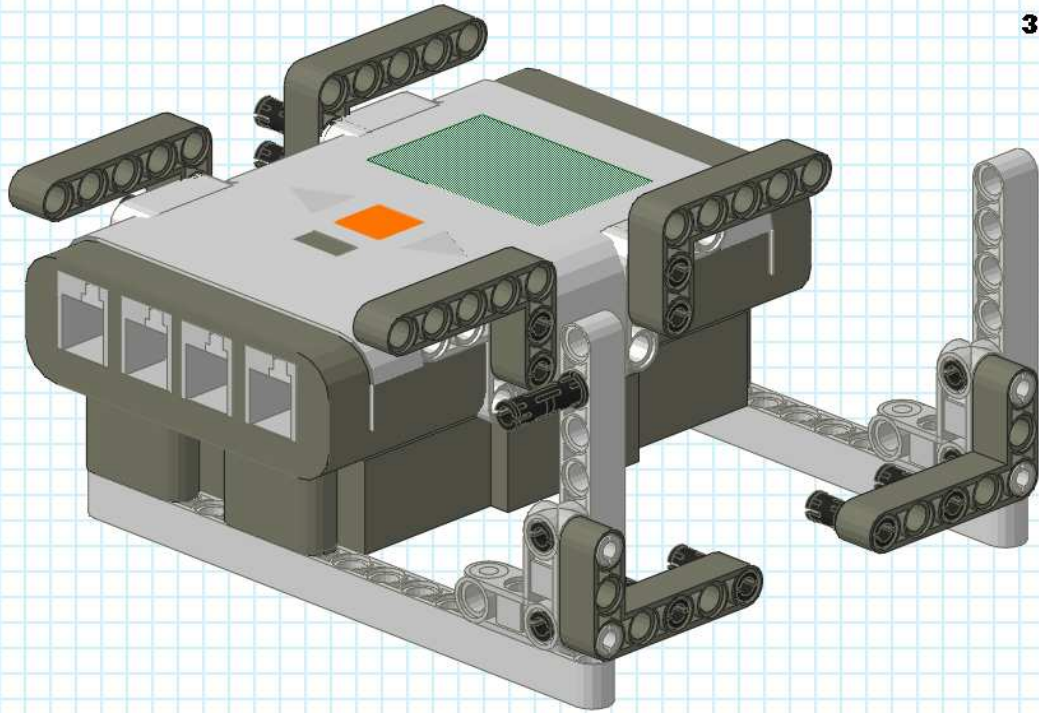
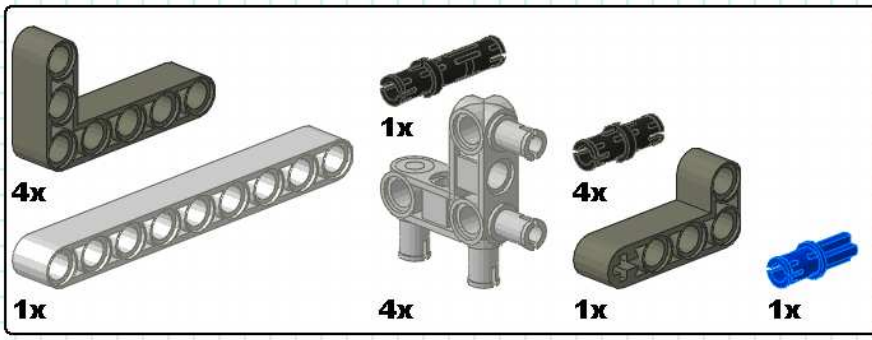
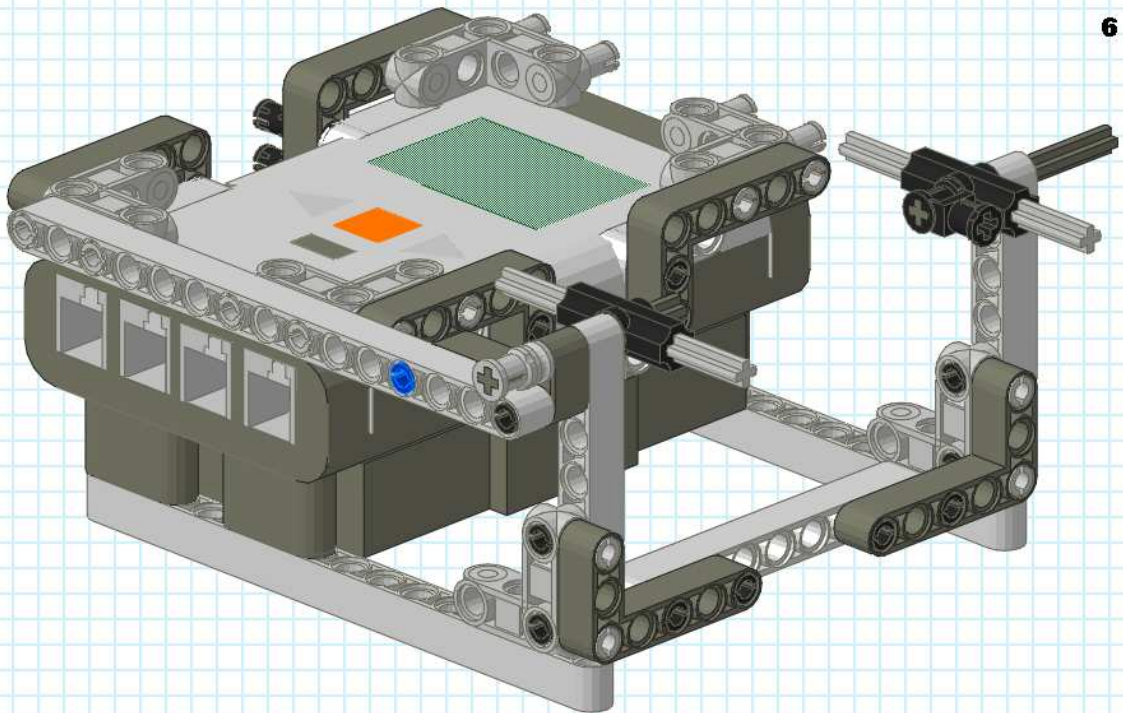
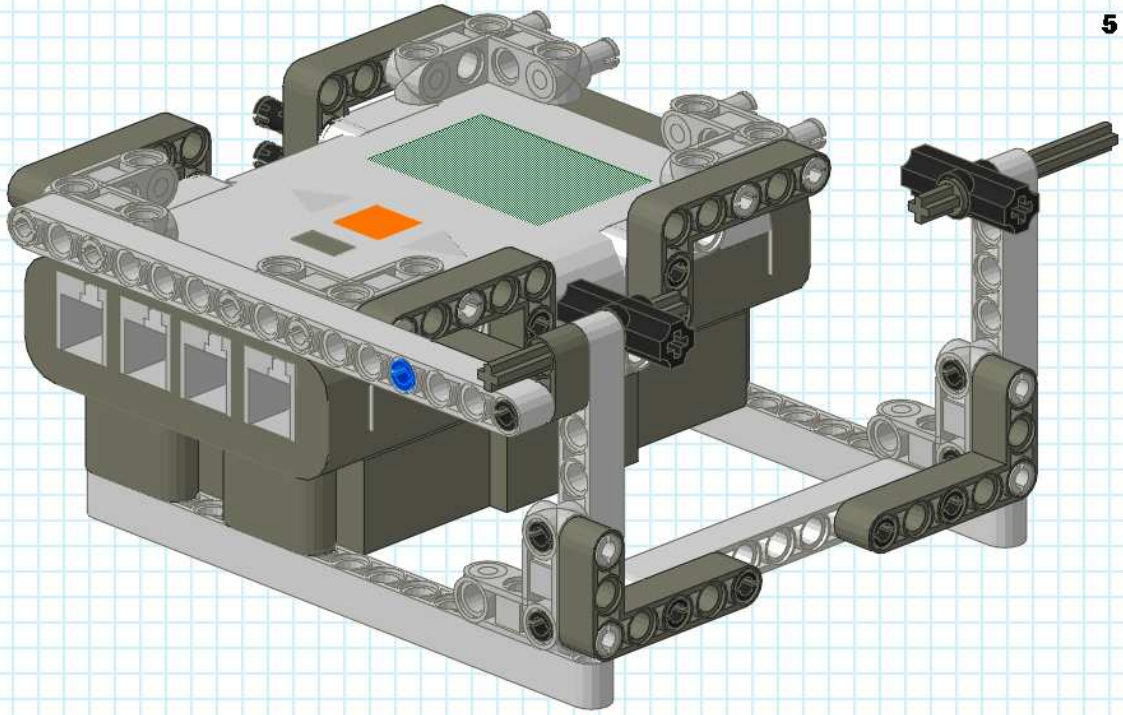
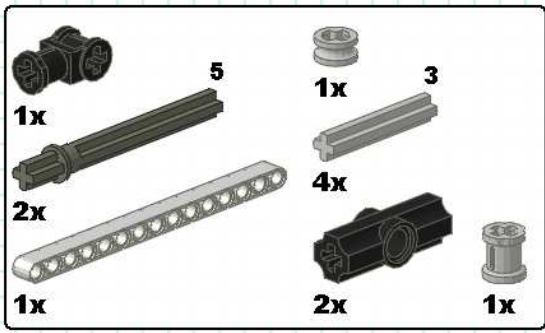

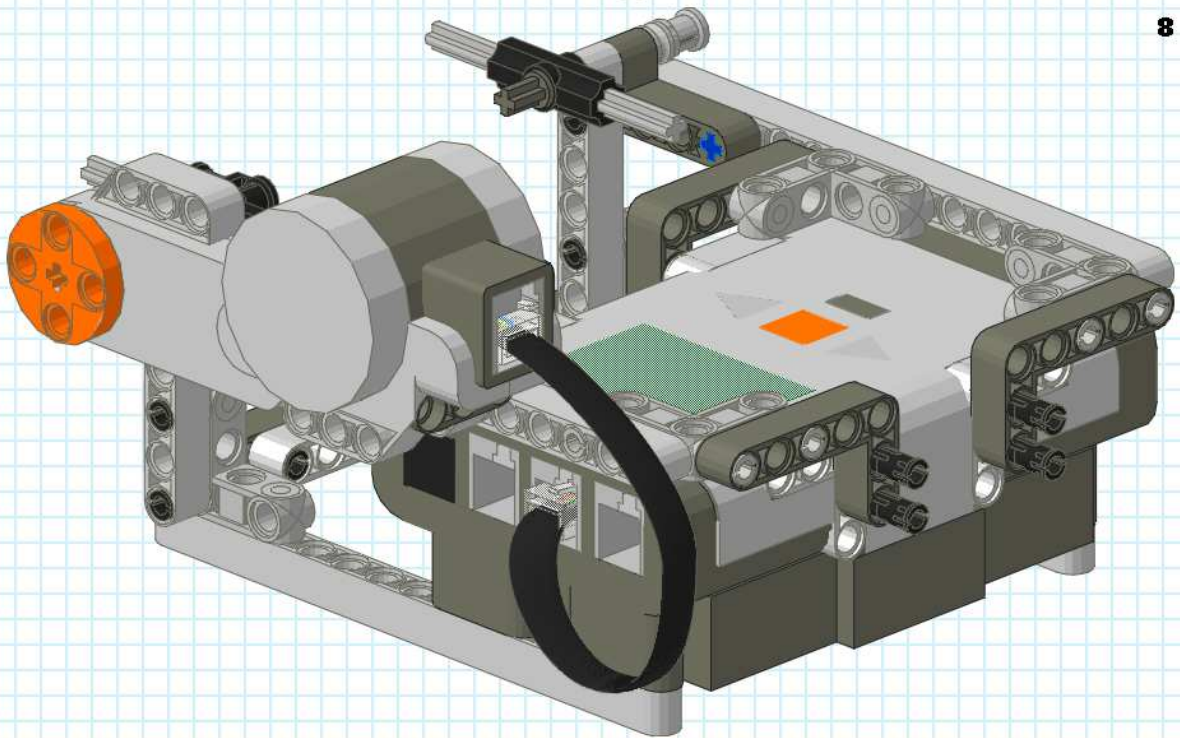
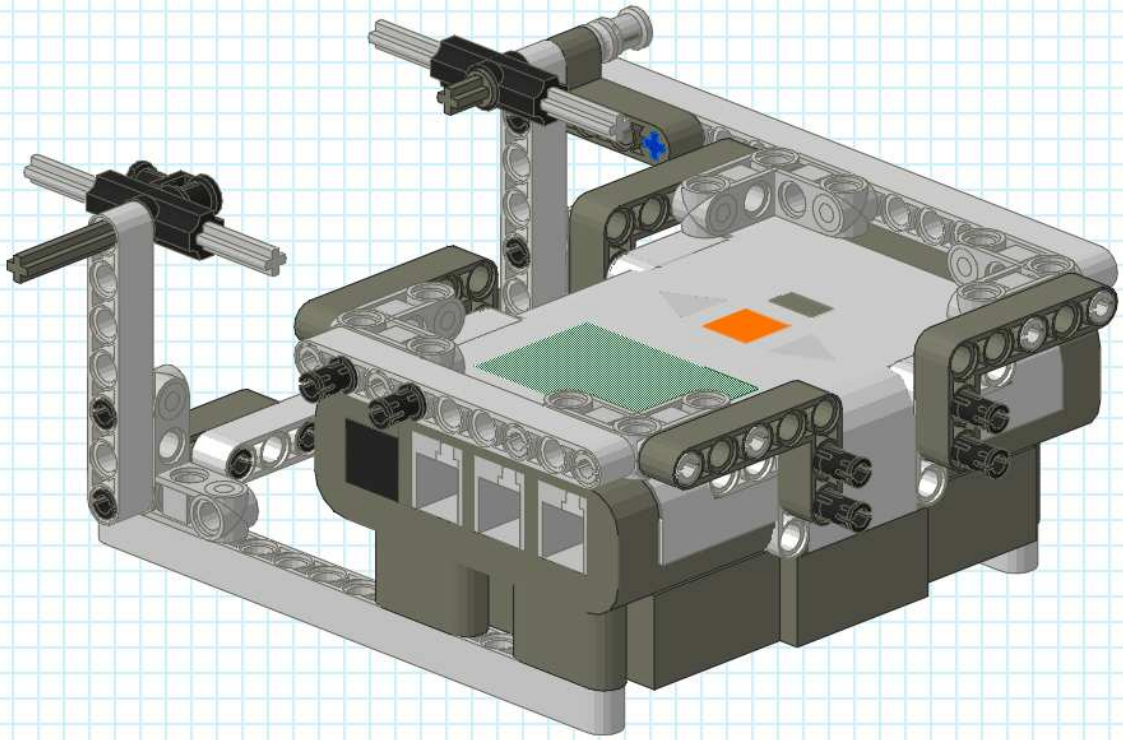
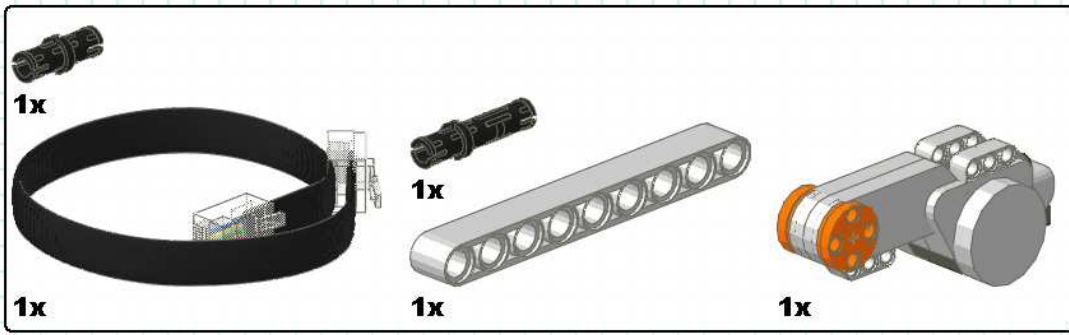

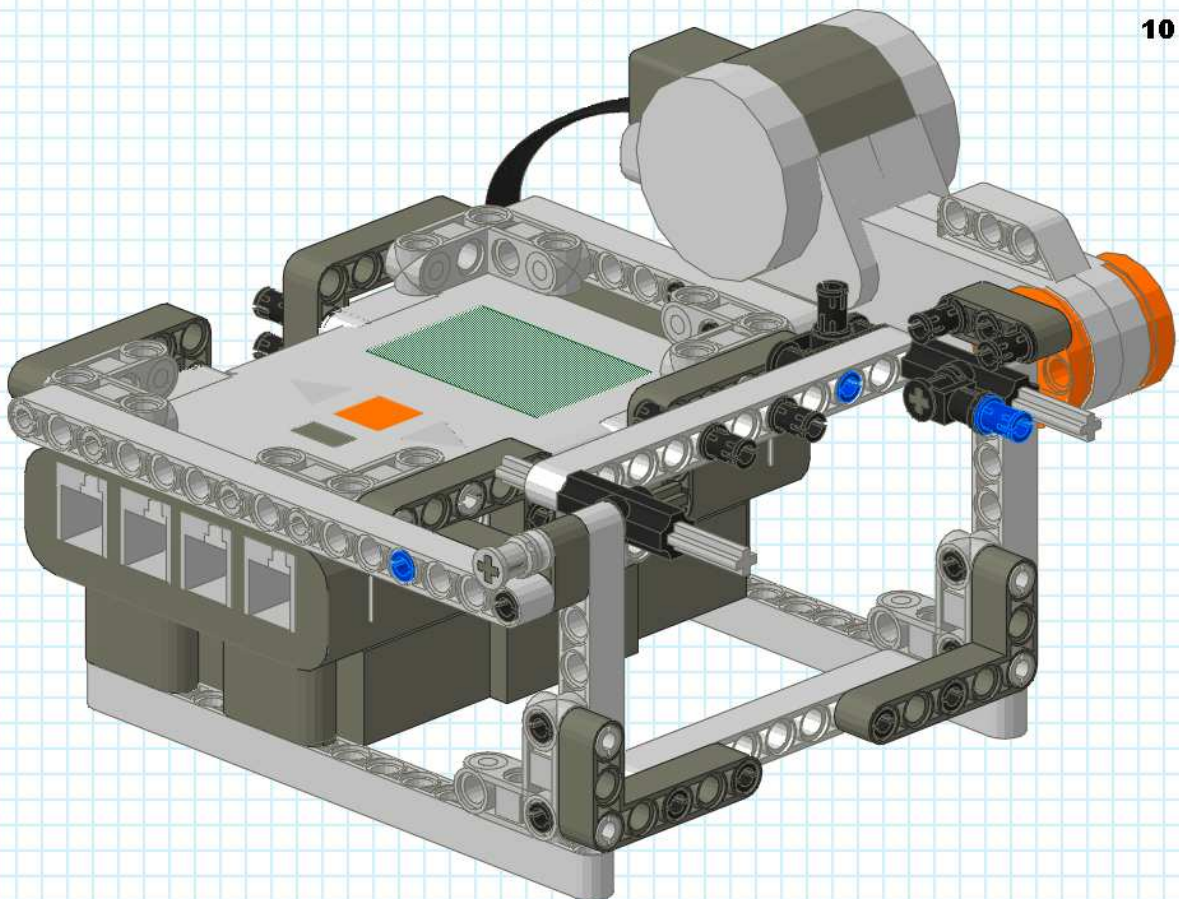
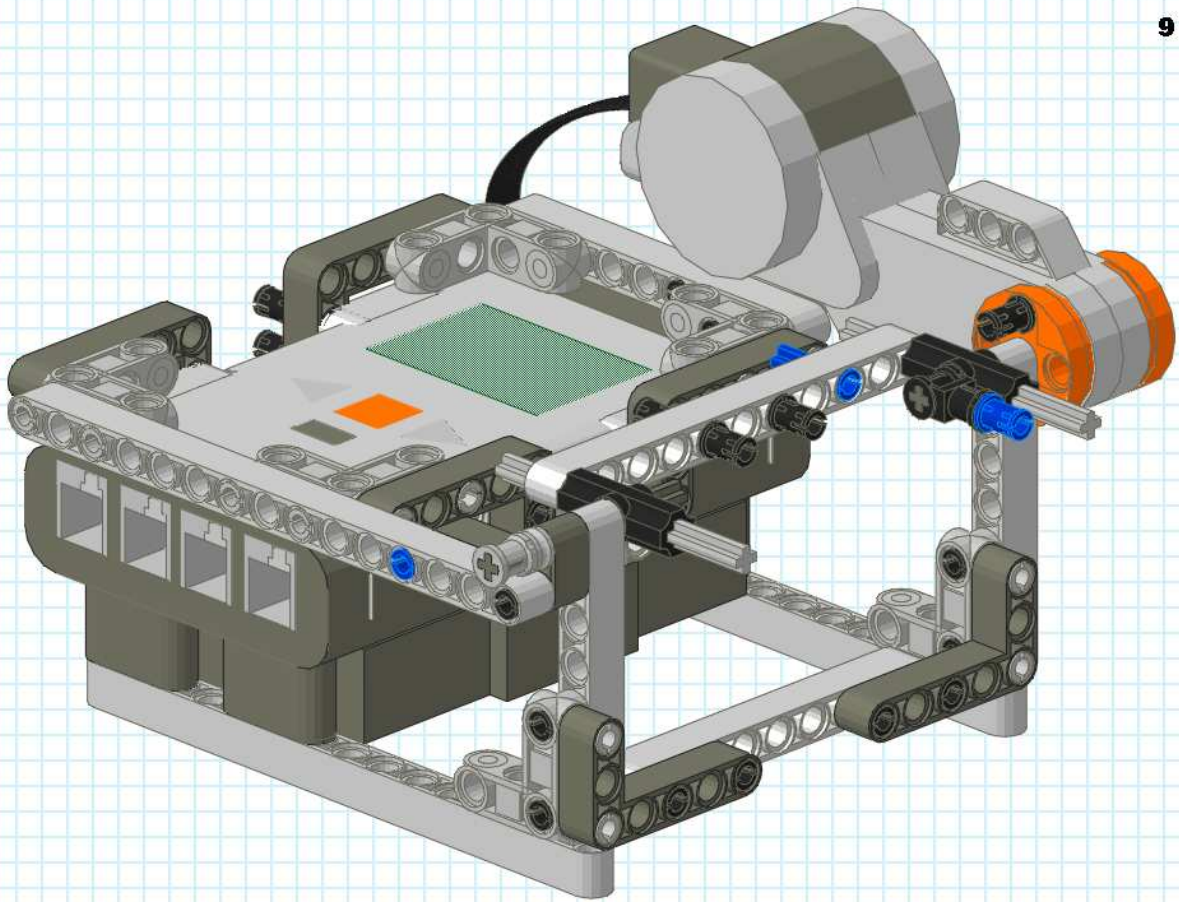
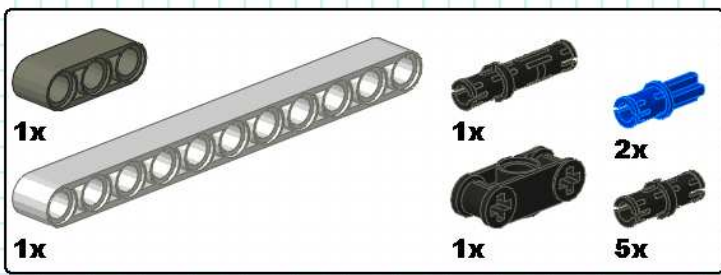

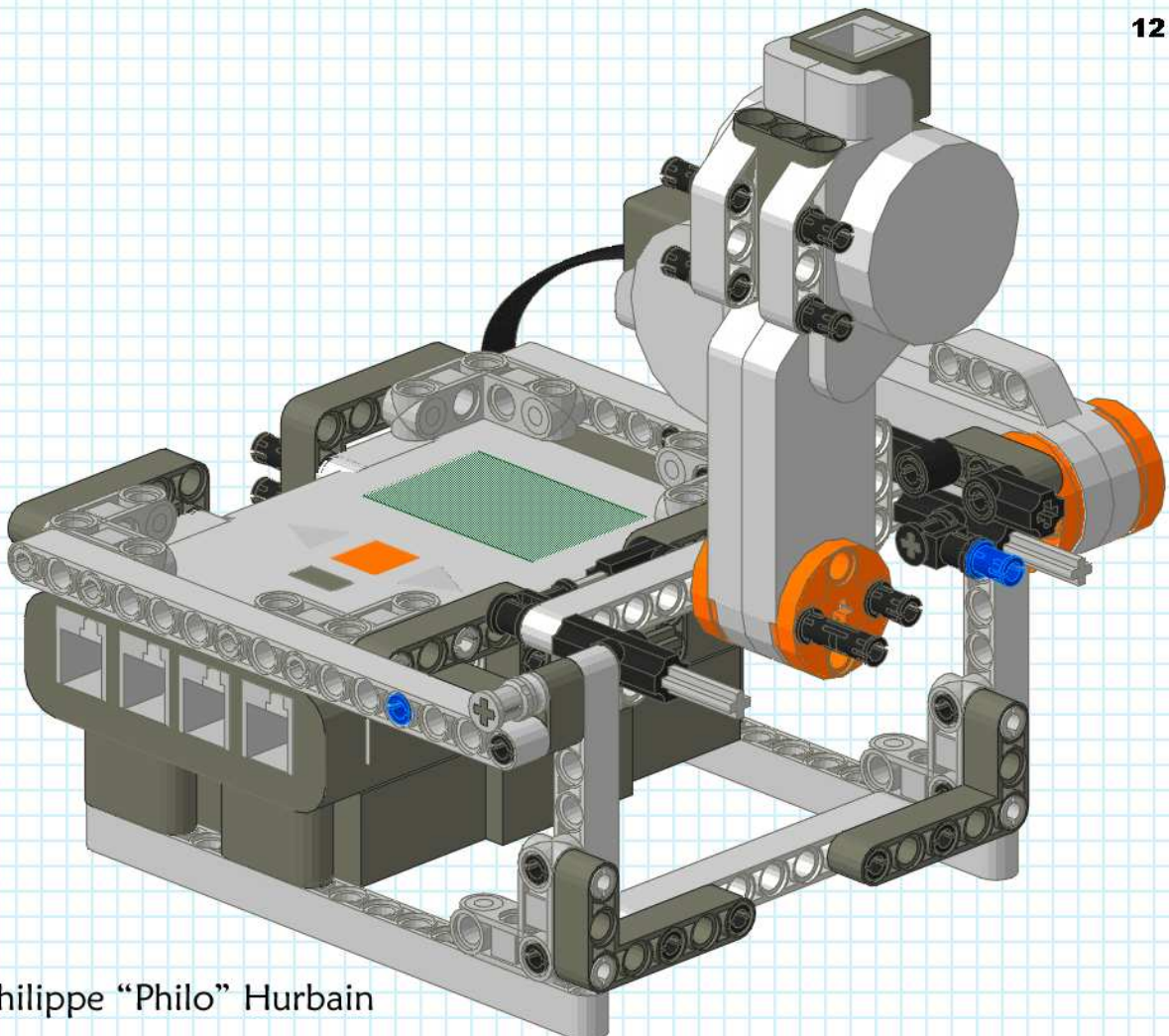
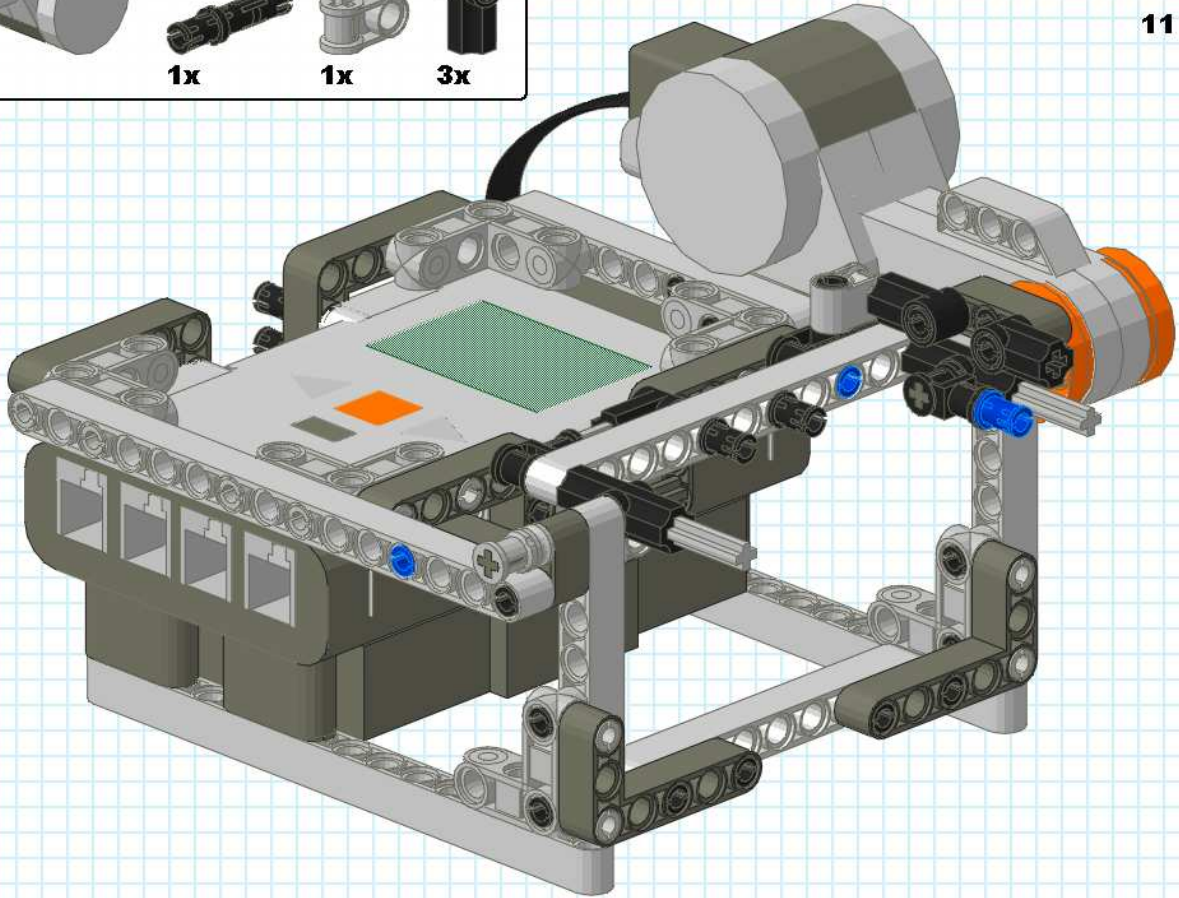
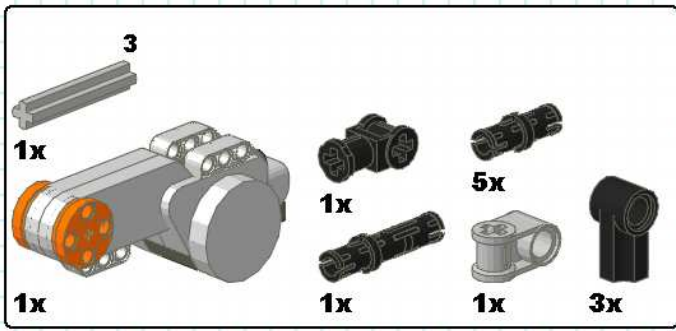

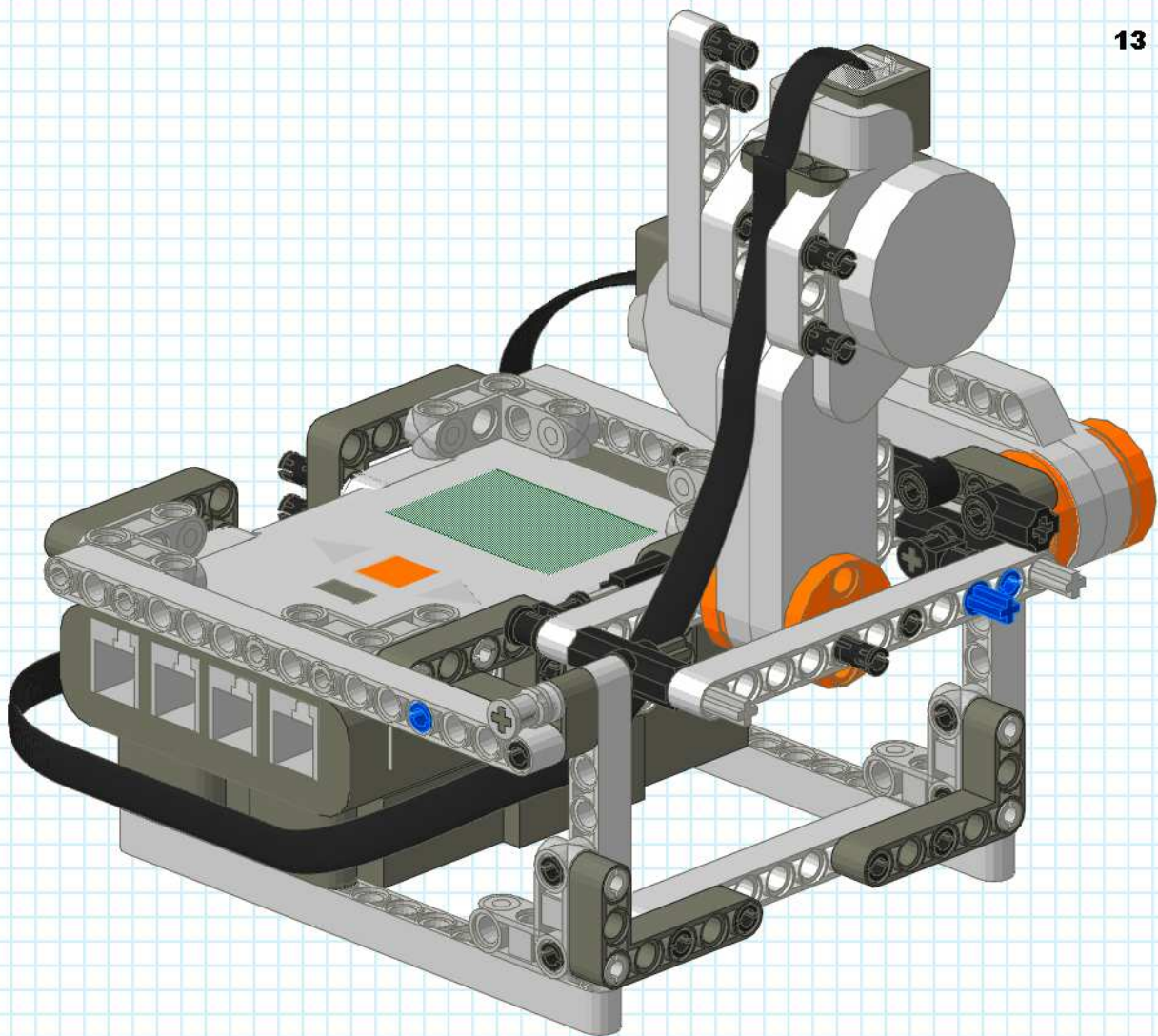
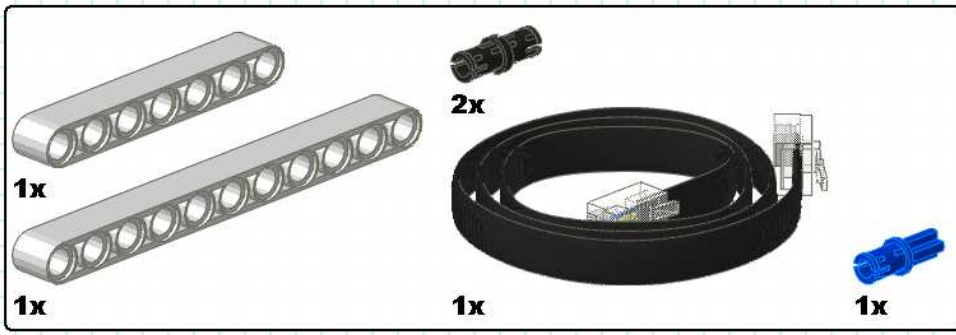

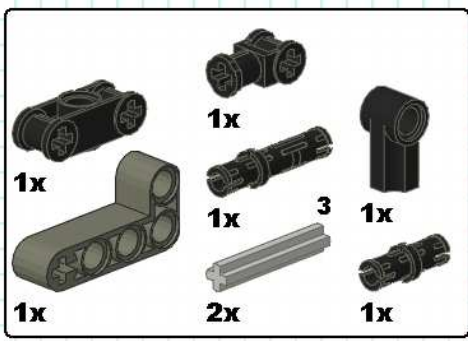

14

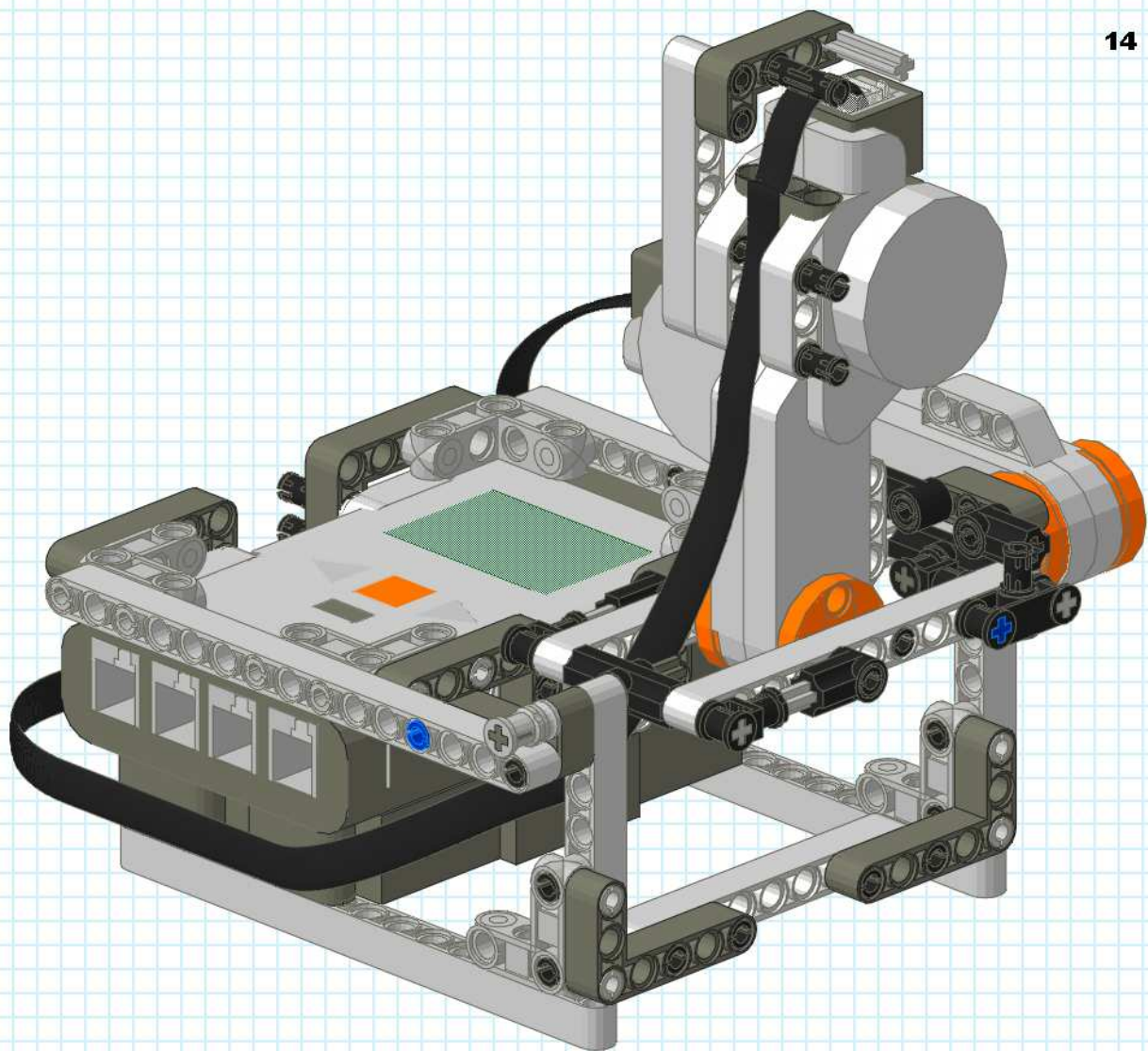

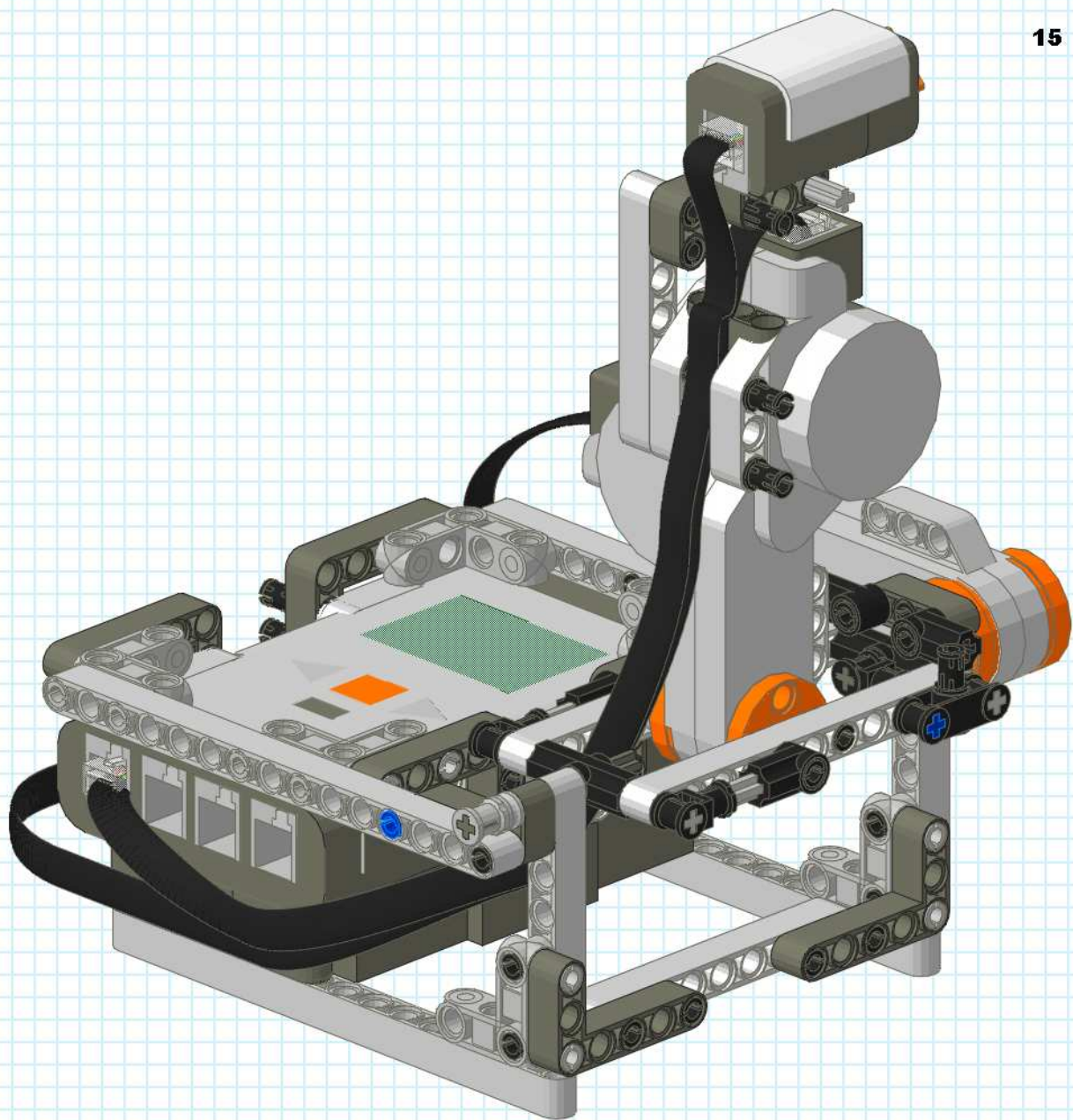
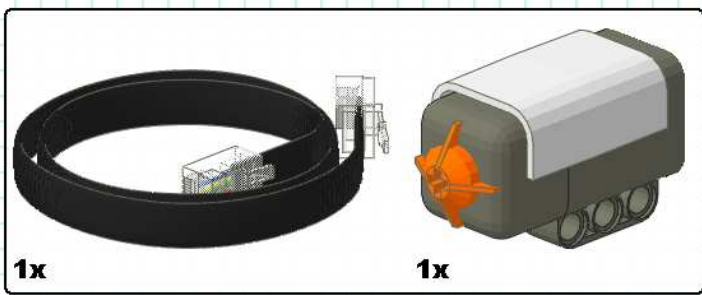

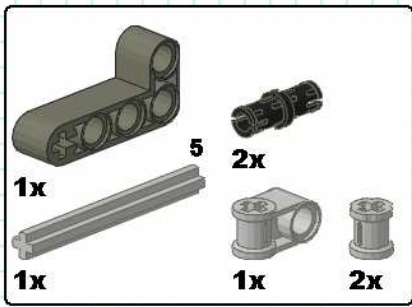

16

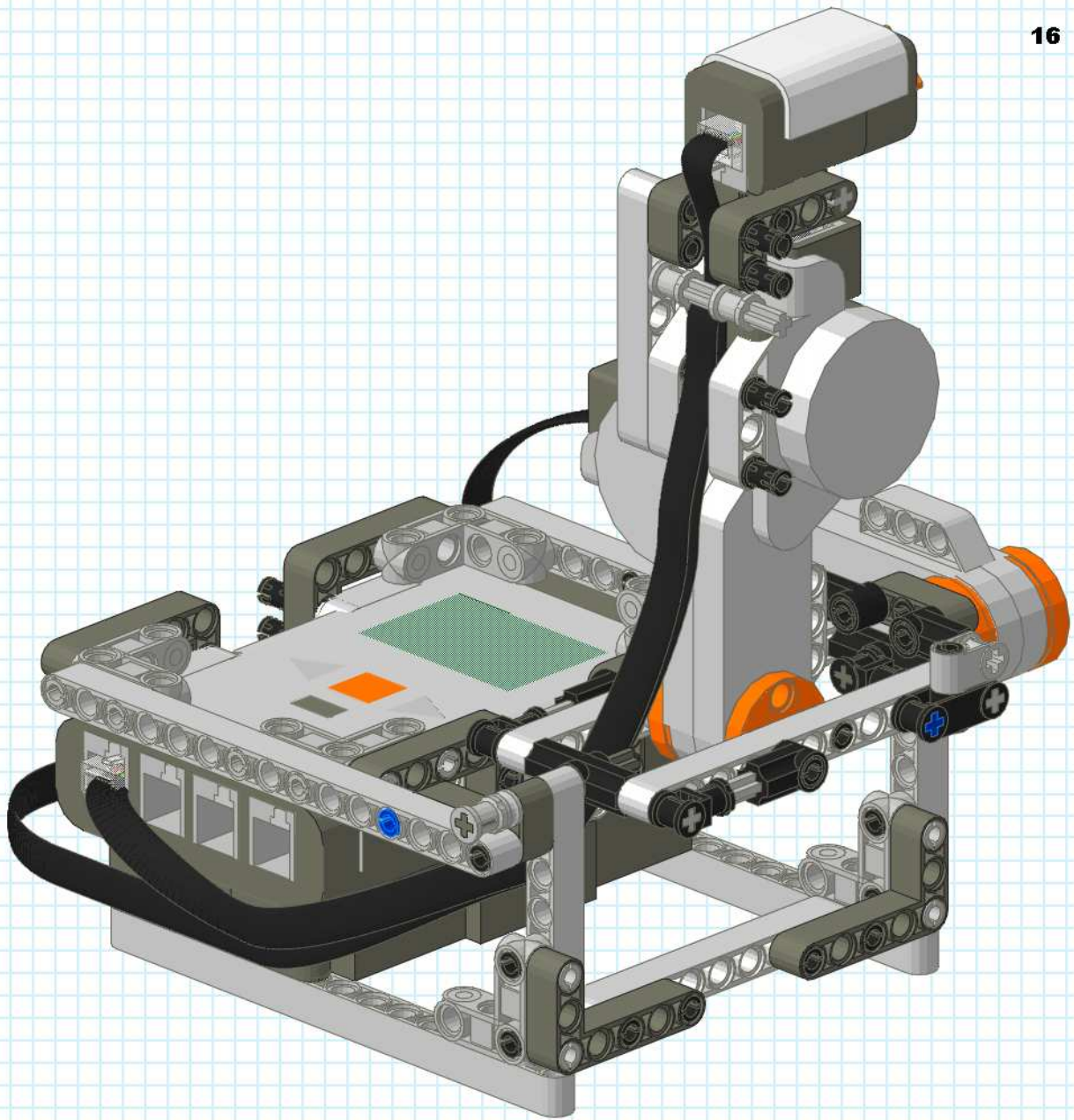

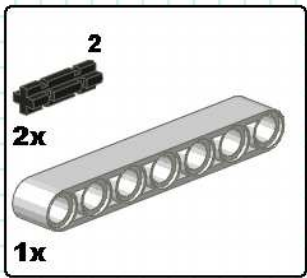

17

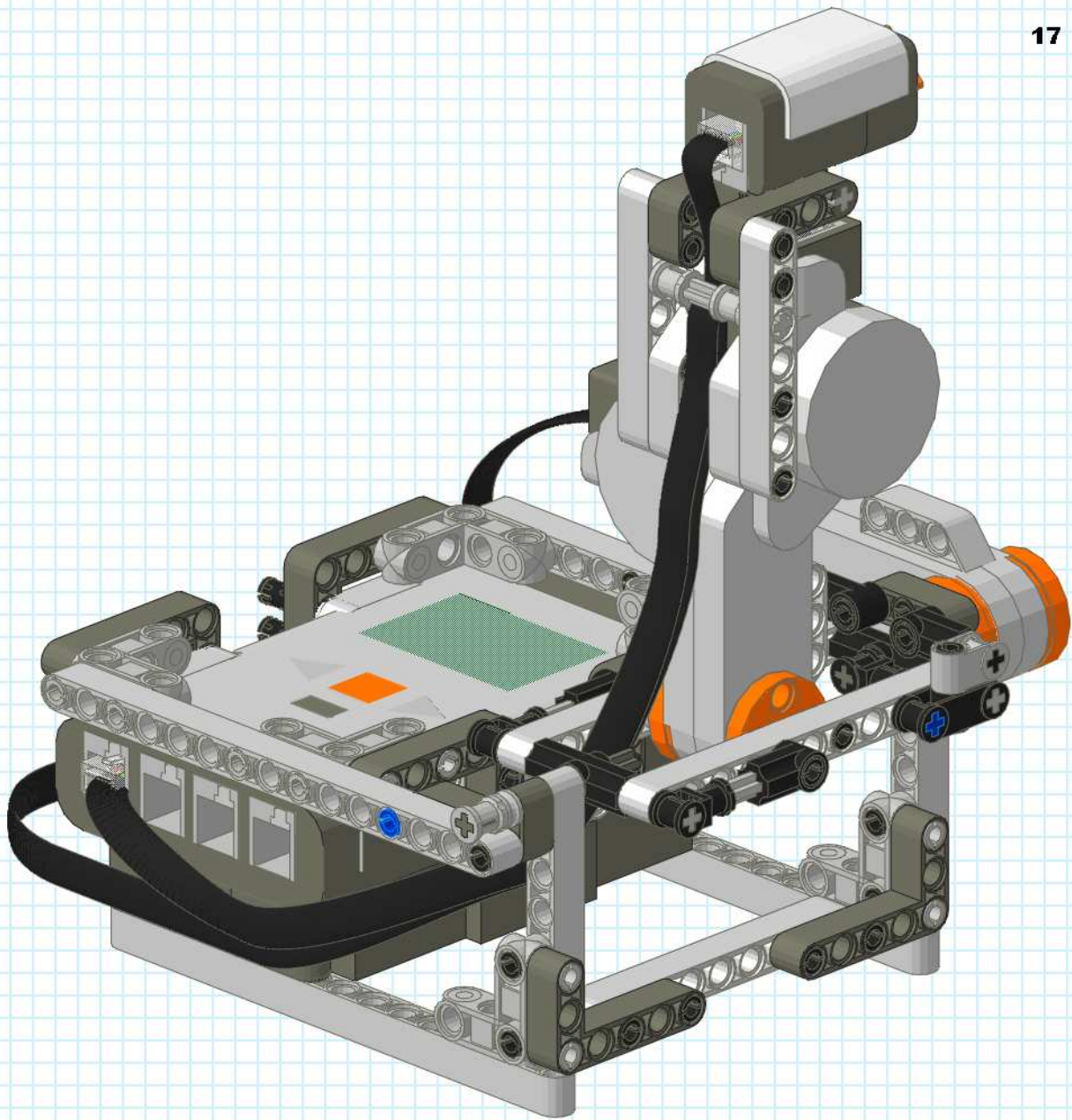



18

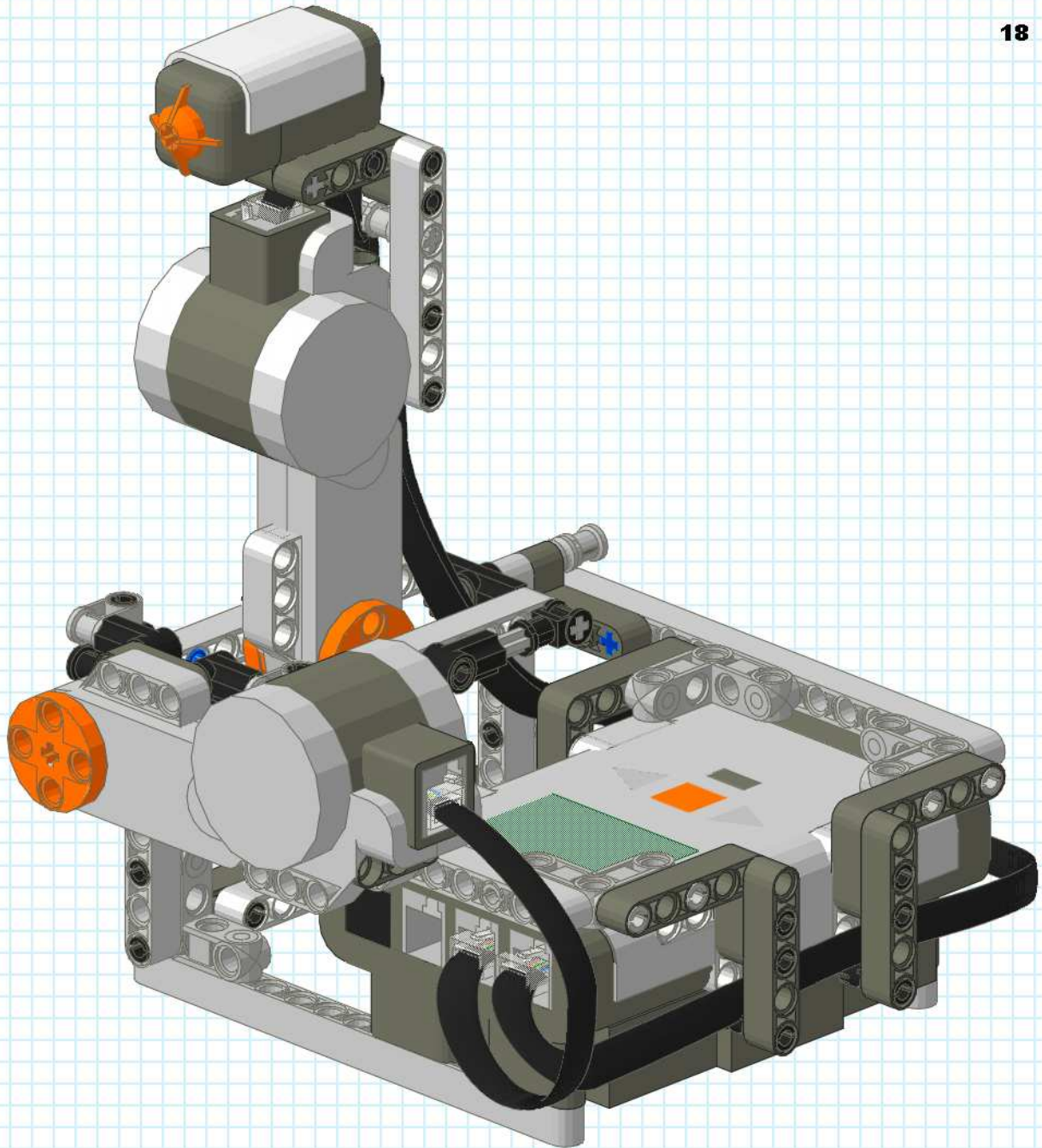

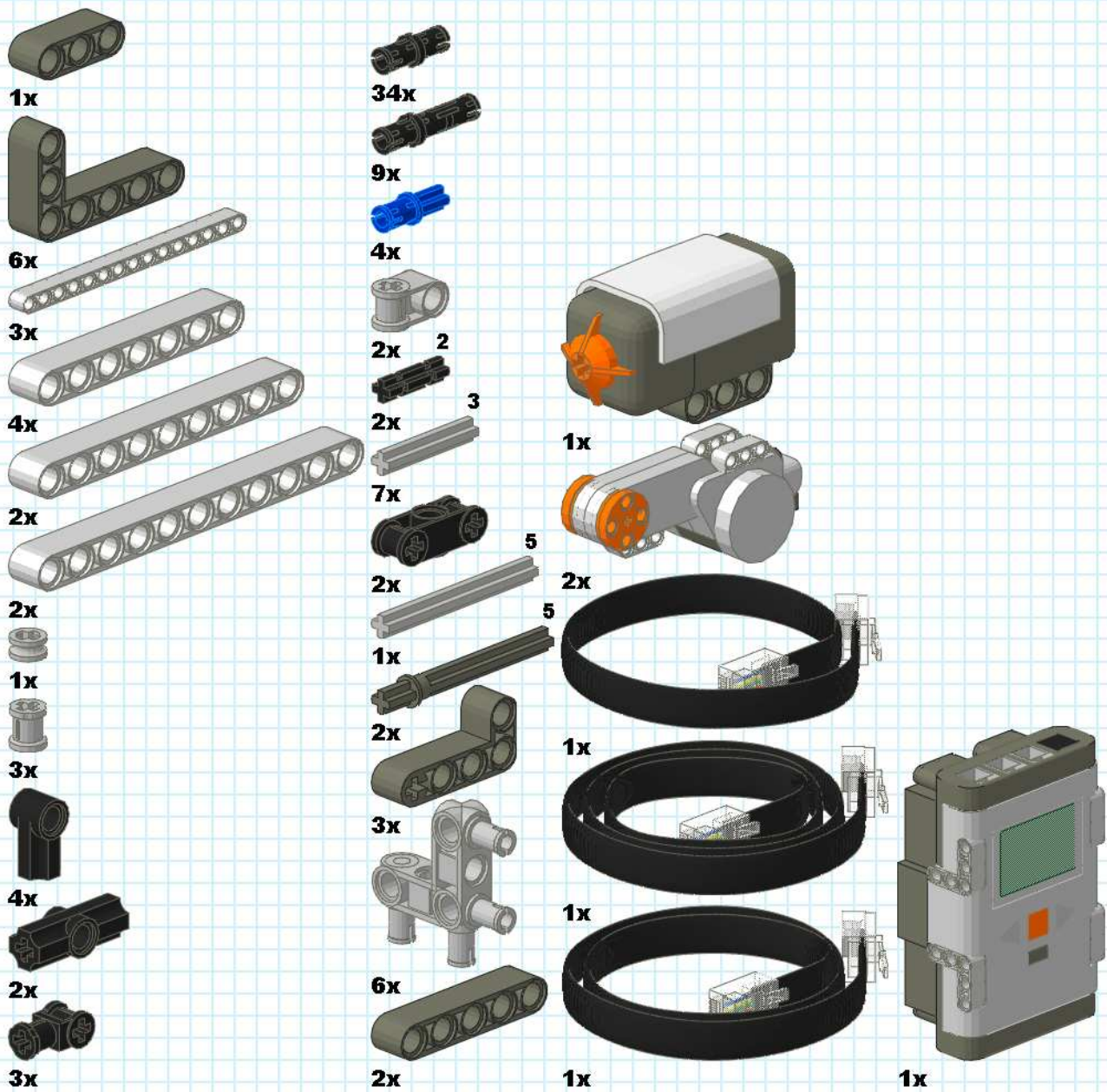

Tools

Initial Modelling: LeoCAD
www.leocad.org

MPD building, arrows: MLCad
<http://www.lm-software.com/mlcad/>

Publishing tool: LPub
<http://www.kclague.net//LPub/>

Renderer: LdGLite
<http://ldglite.sourceforge.net/>

*Special thanks to the guys behind these great tools,
 and to the numerous LDraw parts authors.*